



LSP-400 Series Lift Station

The Brac Systems LSP-400 Lift Station has been engineered to be compatible with the Brac Greywater Recycling Systems. Since all greywater system installations are unique, certain instances may require the use of a lift station. For example, the LSP-400 would be used when the CGW Commercial filter housings are separated by distance from the main holding tank or when there is insufficient grade to allow the greywater to flow by gravity to the filter housings. Another example would be for an SGW-2000 installation, the LSP-400 would be used to bring the greywater up from below grade to the inlet of the Brac tank.

All Brac Systems lift Stations come preassembled and ready to plug-in. The one-piece Polyethylene construction ensures the units are watertight, eliminating the risk of seepage and infiltration. The lightweight, robust and durable LSP-400 offers easy and secure access to internal components. Also available is a 14" riser adapter for deeper installations.

PRICE: CAD\$1,799.00

FEATURES:

- PolyEthylene (PE) tank construction
- Audio/visual alarm system (CSA approved)
- 0.5hp greywater sump pumps (CSA approved)
- Weight: 50 kg (110 lbs)
- Inlet: fits 4" SDR or SCH40 PVC pipes
- Outlet: fits 2" SDR or SCH40 PVC pipes

TECHNICAL DATA SHEET

HEAD	L/MIN	HEAD US	GPM
6.7 m	126	22'	33
6.0 m	202	20'	53
4.5 m	290	15'	77
3.0 m	360	10'	95
1.5 m	403	5'	107

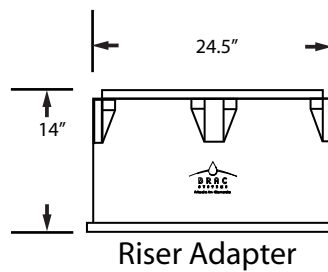

FRICION LOSS IN PIPE NOT INCLUDED

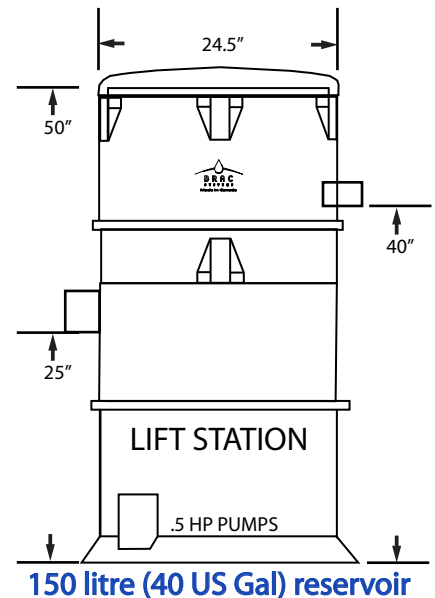

RELIABLE AND RESISTANT LIFT STATIONS!

The content of this Data Sheet is based upon the latest information available at the time of printing and is aimed at providing a general introduction to Brac Systems products. No warranty or representation is hereby made by Brac Systems as to the accuracy of said information. Brac Systems is continually updating and improving its products and reserves the right to amend, discontinue, alter or change specifications and prices without prior notice.